

Insieme

STRUCTURAL FEATURES

PRODUCT DATA SHEET

STRUCTURE thickness 7/8", TOP thickness 5/8" and FRONTS thickness 7/8" and 1 3/8" in *wood particle board panels coated with synthetic melamine also matt, glossy lacquered or metal or with painted wood veneer. With "gloss front panel" we refer to the external side and its gloss edges, while the interior is supplied with the corresponding matt lacquered colour.

BACK PANELS in medium density *wood particle board panels thickness 1/4" with synthetic melamine.

TURN DRAWER thickness 5/8" and BOTTOM thickness 3/8" in *wood particle board panels with melamine Tramato Juta.

Opening through a side groove in the same colour as the structure when lacquered or with the proposed combinations in all other cases.

Black ABS FEET, diam. 1 7/8", height 1 1/8", 1/2" adjustable from the inside.

*Wood and derivatives components according to the following standards: EPA TSCA TITLE VI.

RUNNERS FOR DRAWERS

Opening with side grip: High sliding full extraction metal runners with FULL EXTRACTION, end-of-run buffer with dynamic capacity of 30 kg. "Blumotion" soft-closing mechanism integrated in the runner for a silence and soft closing system. Anti-tilting pin, vertical and inclination adjustment of fronts incorporated in all system runners. Additional stabilizer bar for drawers width 29 5/8" and 35 1/2" and "MOVENTO" runners with built-in stabilizer and also front side adjustment for drawers width 47 1/4" and 59 1/8".

DRAWER UNITS ARE DELIVERED WITH A NON-TILTING DEPTH ADJUSTMENT BRACKET TO BE FIXED TO THE WALL.

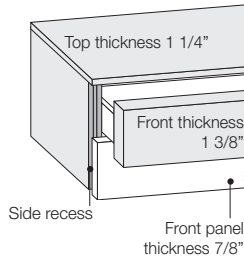
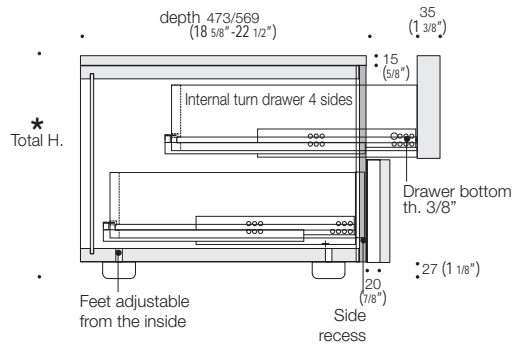

Insieme

Structural types

BEDSIDE TABLES

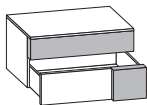
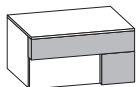

Front with double thickness
1 3/8"-7/8" joined to an
internal turn drawer

DRAWER CHESTS

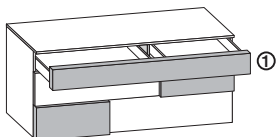
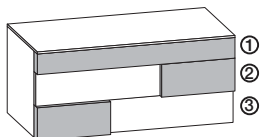

1 3/8" front panel
With double turn drawer

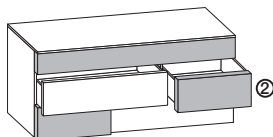

1 1 3/8" front panel
1 7/8" front panel
With 2 splitted turn drawers

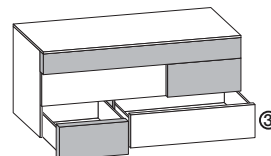

1 1 3/8" front panel
1 7/8" front panel
With 2 splitted turn drawers

UNIT WITH 6 DRAWERS

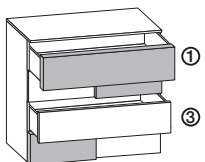
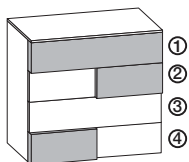

① 1 3/8" front panel
③ 7/8" front panel
With internal turn drawer

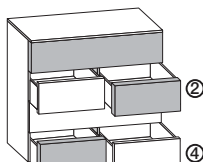

② Front Th. 1 3/8"-7/8"
④ Front Th. 1 3/8"-7/8"
With 2 splitted turn drawers

MATCHING THE SIDE RECESS GRIP WITH THE STRUCTURE

CARCASS:

OAK Carbone
OAK Argilla
OAK Grigio
OAK Cenere
ROVERE NODATO Naturale
ROVERE NODATO Caramello
NOCE CANALETTO

Matt LACQUERED
Matt LACQUERED frassinato
Glossy LACQUERED
Metal LACQUERED

MELAMINE FINISH Olmo Scuro
MELAMINE FINISH Loto Natura
MELAMINE FINISH Loto Tortora
MELAMINE FINISH Loto Terra
MELAMINE FINISH Frassinato Bianco 10
MELAMINE FINISH Frassinato Canapa

SIDE RECESS:

BROWN
Matt TERRANOVA
BROWN
PIOMBO
BROWN
BROWN
BROWN

Matt LACQUERED
Matt LACQUERED
Glossy LACQUERED
Metal LACQUERED

BROWN
Matt GRIGIO CORDA
Matt GRIGIO CORDA
Matt TERRANOVA
Matt BIANCO 10
Matt CANAPA