

## Status

### STRUCTURAL FEATURES

#### PRODUCT DATA SHEET

STRUCTURE thickness 7/8" and FRONTS thickness 1 3/8" in \*wood particle board panels coated with synthetic melamine matt, glossy lacquered or metal or with painted wood veneer. With "gloss front panel" we refer to the external side and its gloss edges, while the interior is supplied with the corresponding matt lacquered colour.

BACK PANELS in medium density \*wood particle board panels thickness 1/4" with synthetic melamine.

TURN DRAWER thickness 5/8" and BOTTOM thickness 3/8" in \*wood particle board panels with melamine Tramato Juta.

Opening through a side groove edged by a metal profile supplied with ceramic tops.

Ceramic TOP made of 1/2" thick x 63 7/8"x127 5/8" slabs cut at random in terms of dimensions and pattern direction. Scratchproof and highly abrasion resistant, these tops are eco-compatible and do not release dissolved elements

Black ABS FEET, diam. 1 7/8", height 1 1/8", 1/2" adjustable from the inside.

\*Wood and derivates components according to the following standards: EPA TSCA TITLE VI.

#### RUNNERS FOR DRAWERS

**Opening with side grip:** High sliding full extraction metal runners with FULL EXTRACTION, end-of-run buffer with dynamic capacity of 30 kg. "Blumotion" soft-closing mechanism integrated in the runner for a silence and soft closing system. Anti-tilting pin, vertical and inclination adjustment of fronts incorporated in all system runners. Additional stabilizer bar for drawers width 29 5/8" and "MOVENTO"runners with built-in stabilizer and also front side adjustment for drawers width 47 1/4".

#### DRAWER UNITS ARE DELIVERED WITH A NON-TILTING DEPTH ADJUSTMENT BRACKET TO BE FIXED TO THE WALL.

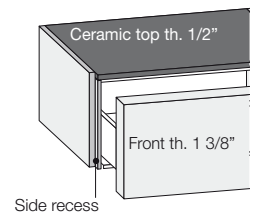
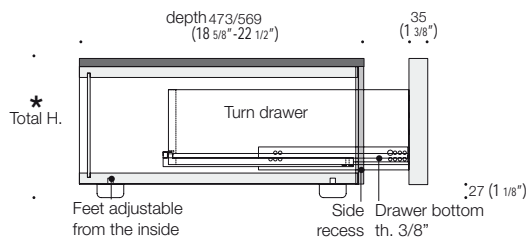

#### TYPE OF STRUCTURE

Bedside table with 2 drawers

3-drawer chest

Drawer chest with 2 drawer units placed side by side

Unit with 6 drawers

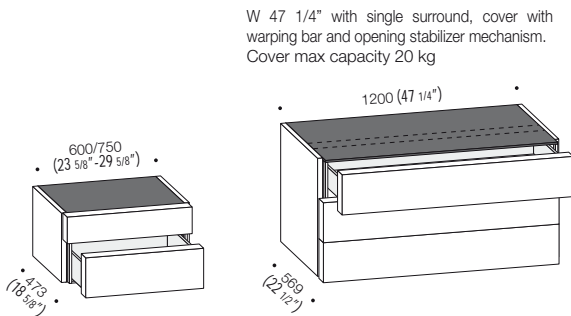

W 47 1/4" with single surround, cover with warping bar and opening stabilizer mechanism. Cover max capacity 20 kg

